

# 7.5" modero® viewpoint touch panel



## **MVP PERFORMANCE**

AMX proudly expands its highly successful Modero family of Touch Panels: With the 7.5" Modero ViewPoint Touch Panel (MVP-7500). This 802.11b-based wireless handheld panel, which includes a number of features and useful accessories, is just the right size for convenient, comfortable one-touch control in any integrated environment.

## **WIRELESS CONVENIENCE**

Experience high-end control capabilities without the wires. A fully compatible standard 802.11 Wi-Fi Card provides additional control features and eliminates the inconvenience of installing and using cables. Both 38KHz and 455KHz 1-way IR are also built in. The MVP-7500 provides dealers a clean, seamless, unobtrusive touch panel solution. For end users, the ability to take control from anywhere, at any time.

## **G4 COMPUTER CONTROL™**

The AMX exclusive Computer Control delivers remote access and control of any networked computer directly to the MVP-7500. Launch digital music on your MP3 player. Cruise the Internet. Check and respond to email. Open software files and launch applications. Anything that can be done on the PC can now be accomplished through the MVP-7500, all at the simple touch of a button.



# 7.5" modero® viewpoint touch panel

## MVP-7500 (FG5965-01)

### LCD

- 7.5" Color passive-matrix (600 x 480 pixel resolution)
- Display colors: 4,096 (12-bit color depth)
- Brightness: 120 cd/m2
- Contrast: 20:1
- Anti-glare Overlay
- Aspect Ratio: 4 x 3

### POWER

- Operates with 1 or 2 MVP-BP battery packs (1 included)
- 12-18 VDC Power Supply for recharging batteries

### MEMORY

- 64MB SDRAM
- 64MB Compact Flash (upgradeable to 1GB)

### DIMENSIONS (HWD)

- 7.17" x 10.47" x 1.34"  
(18.20 cm x 26.60 cm x 3.4 cm)

### INTERFACES

- 802.11 Wireless Ethernet, 2-way network communications
- 38KHz and 455KHz IR
- Mini-USB for programming file transfer
- Docking Station Interconnect
- Power Supply, coaxial barrel connector

### FRONT PANEL

- Front Buttons: 9 programmable buttons

- Programmable LEDs: 1 through front panel  
1 through stylus

### WEIGHT

- 2.65 lbs- Panel with 2 Batteries (1.20kg)
- Included Accessories:
  - (1) MVP-BP (FG5965-20)
  - PS4.4 (FG423-44)
  - Stylus
  - Quick Start Guide

### OPTIONAL ACCESSORIES

- MVP-TDS, Table Top/Tilt Docking Station (FG5965-10)
- MVP-WDS, Wall/Flush Mount Docking Station (FG5965-11)
- MVP-KS, Kickstand (FG5965-12)
- MVP-BP, Spare Battery Pack (FG5965-20)
- PS4.4, Power Supply (FG423-44)
- PSN4.4, Power Supply (FG423-45)
- MVP-STYLUS, Pack of 3 Stylus (FG5965-30)
- CB-MVPWDS, Conduit Box for MVP, Wall/Flush Mount Docking Station
- CC-USB, Programming Cable (FG10-5965)
- NXA-75CF128M, 128M Compact Flash (FG2116-55)
- NXA-75CF256M, 256M Compact Flash (FG2116-56)
- NXA-75CF512M, 512 Compact Flash (FG2116-57)
- NXA-75CFIG, IG Compact Flash (FG2116-58)

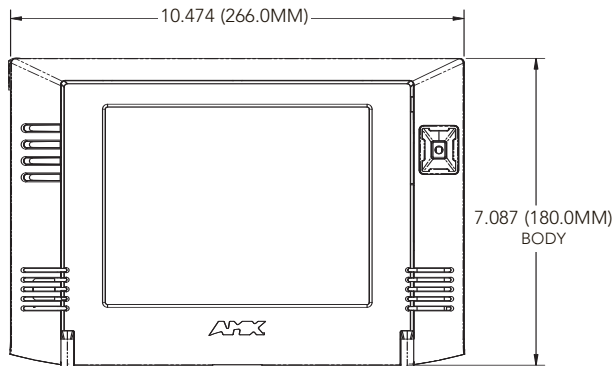

MVP-7500 (Front View)

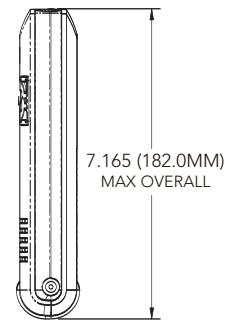

MVP-7500 (Right Side)



MVP-7500 (Bottom View)

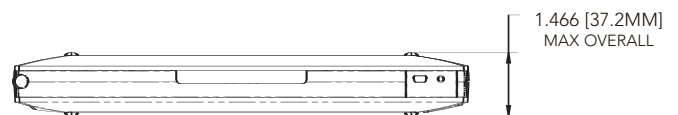

MVP-7500 (Top View)



IT'S YOUR WORLD. TAKE CONTROL.

ARGENTINA • AUSTRALIA • BELGIUM • BRAZIL • CANADA • CHINA • ENGLAND • FRANCE • GERMANY • GREECE • HONG KONG • INDIA • INDONESIA • ITALY • JAPAN  
LEBANON • MALAYSIA • MEXICO • NETHERLANDS • NEW ZEALAND • PHILIPPINES • PORTUGAL • RUSSIA • SINGAPORE • SPAIN • SWITZERLAND • THAILAND • TURKEY • USA  
ATLANTA • BOSTON • CHICAGO • CLEVELAND • DALLAS • DENVER • INDIANAPOLIS • LOS ANGELES • MINNEAPOLIS • PHILADELPHIA • PHOENIX • PORTLAND • SPOKANE • TAMPA  
3000 RESEARCH DRIVE, RICHARDSON, TX 75082 • 800.222.0193 • 469.624.8000 • +1.469.624.7400 • 469.624.7153 fax • www.amx.com