

Modero® Touch Panels

8.4" Modero ViewPoint® Touch Panel



The MVP-8400 is a clean, seamless, unobtrusive touch panel that combines Wall/Flush Mount flexibility, table top functionality and wireless mobility that gives users the ability to take control from anywhere, at any time. A fully compatible standard 802.11 Wi-Fi Card provides additional control features and eliminates the inconvenience of installing and using cables. Additionally both 38KHz and 455KHz 1-way IR are also built in.

COMMON APPLICATION

The perfect user interface for whole home automation of high-rise residences, luxury MDUs, boutique hotels and other applications requiring a sophisticated interface.

FEATURES

- 8.4" color active-matrix TFT with 4 x 3 Aspect Ratio
- Screen Resolution (HV): 800 x 600 pixels with Anti-glare Overlay
- Display colors: 262 K (18 bit color depth)
- Built-in speakers (2) and microphone
- 64 MB RAM/64 MB CompactFlash Memory (upgradeable)
- 802.11g WiFi for two-way network communications
- Nine programmable hard buttons
- Operates with two MVP-BP Battery Packs
- 12 VDC Power Supply for recharging batteries



MVP-8400 (FG5965-05)

DIMENSIONS (HWD)

7 3/16" x 10 1/2" x 1 1/4" (18.2 cm x 26.6 cm x 3.1 cm)

WEIGHT

- 2.0 lbs (0.91 kg)
- Panel with one battery: 2.25 lbs (1.02 kg)
- Panel with two batteries: 2.65 lbs (1.20 kg)

SCREEN PROPERTIES

- Screen resolution: 800 x 600 pixels (HV) @ 60 Hz frame frequency
- Aspect ratio: 4 x 3
- Brightness (luminance): 180 cd/m2
- Channel transparency: 8-bit Alpha blending
- Contrast ratio: 350:1
- Display colors: 256K colors (18-bit color depth)
- Dot/pixel pitch: 0.21 mm
- Panel type: TFT Color Active-Matrix

VIEWING ANGLE

Vertical: + 60° (up from center) and - 40° (down from center)

POWER REQUIREMENT (without charging)

- Panel with batteries fully charged or with no batteries:
- Constant current draw: 1.2 A @ 12 VDC
- Startup current draw: 1.8 A @ 12 VDC
- If panel is mounted onto a TDS or WDS, add 0.1 A to the above figures.

POWER REQUIREMENT (while charging)

- Panel while charging batteries:
- Constant current draw: 3.2 A @ 12 VDC
- Startup current draw: 3.8 A @ 12 VDC
- If panel is mounted onto a TDS or WDS, add 0.1 A to the above figures.

MINIMUM POWER SUPPLY REQUIRED

PS4.4 Power Supply (FG423-45) - All MVP models are shipped with this power supply

POWER MODES

- ON: Panel is fully functional.
- STANDBY: Panel uses low power, the LCD/backlight is shutdown, LEDs still function. Panel resumes the ON mode in ~ 1 second.
- OFF: On-board programs not running, touch screen still powered, LED not functional. Panel resumes the ON mode in ~ 30 seconds.

CERTIFICATIONS

- FCC Part 15 Class B and CE
- IEC60950

MEMORY

- 64 MB SDRAM
- 64 MB Compact Flash (upgradeable to 1 GB) – factory programmed

BATTERY DURATION (using 2 batteries)

- Eight hours of normal use (25% On state, 25% Standby, and 50% Off)
- Four hours of continuous use (continuous On state). The MVP-8400 panel is shipped with two MVP-BP batteries. You must use both batteries to obtain the duration times given above.

OPERATING/STORAGE ENVIRONMENTS

- Operating Temperature: 0° C (32° F) to 40° C (104° F)
- Operating Humidity: 20% - 85% RH
- Storage Temperature: -20° C (-4° F) to 60° C (140° F)
- Storage Humidity: 5% - 85% RH

BTU/HR

155.7

INCLUDED ACCESSORIES

- Wireless Interface Compact Flash card (CF Type 1) (pre-installed into MVP)
- PS4.4 Power Supply (FG423-44)
- Stylus (pre-installed onto the left side of the unit)
- Two MVP-BP Power Packs (FG5965-20)

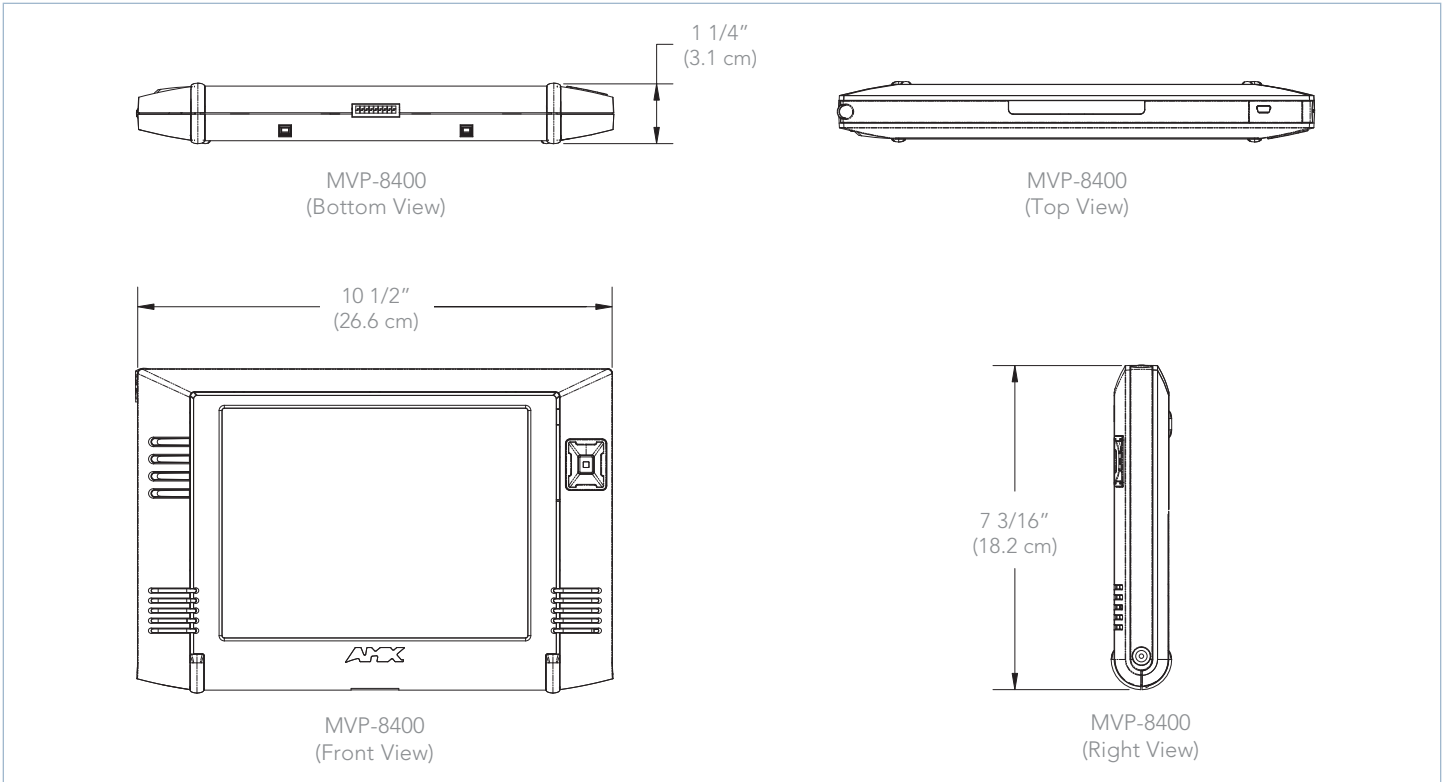

IT'S YOUR WORLD. TAKE CONTROL.